

This technical profile illustrates most residential flashing details. The purpose of flashing is to direct moisture, which has accumulated in the wall system, to the exterior and in so doing, prevent moisture from deteriorating steel angles, timber studs, or other building components. The following details were designed to accomplish both goals. Modifications to these details are normal, however the changes should always focus on the primary objectives for flashing. The following list gives general guidelines for flashing installation and moisture control.

Flashing

- Extend 1" (25 mm) past end of lintels, 4" - 6" (100 - 150 mm) past end of brick sills.
- For non - adhering flashing, cut sheathing board to install, or use plastic straps, or lap under building paper or house wrap.
- Use at least 30 mil (0.75 mm) thick in most situations except where flashing requires end dams, then use 60 mil (1.5 mm).

Note 1: Some building codes and brick industry standards require that the flashing project at least 1/4" (5 mm) beyond the face of the brickwork. Where building codes allow, the flashing can be held back 1/2" (12 mm), provided the flashing is placed on a bed of mortar. Mortar is also placed on top of the flashing. Refer to paper by Paul Perlman on Alternative Flashing Applications to Metal Drip Edges (in Brick Veneer).

Weepholes

- Can be stained cotton rope, open head joints or brick vents.
- Cotton ropes should be spaced 16" o.c. (400 mm); open head joints or brick vents should be spaced 24" o. c. (600 mm).
- The rope used for weepholes should be long enough to tie to a brick anchor.
- Suggest using plastic woven mesh, "Mortar Net" or similar, behind weepholes to help prevent mortar from clogging weeps.

Windows

- It is suggested that windows be either vinyl or aluminum clad. These window frames typically have flanges for fastening the frame to the building. The frames that have a one-piece flange and molding seem to be better at keeping moisture out of the window.
- Arched wood frames, whether semi-circular or palladian, require special flashing consideration. Self-adhering flashing should be cut and molded to fit around the curved portion and adhered to the wood.

Anchors

It is suggested that additional anchors be attached to the frame above the through-wall flashing.

Additional Moisture Protection Steps

- Chimney caps can have either a sloping reinforced concrete cap or a metal cap. If concrete is used, the outside edge should be at least 2" (50 mm) thick and 3" (75 mm) thick at the flue liner. Concrete is preferred over mortar since it is typically 3 times stronger. If a metal cap is used it should fit snugly over the brick and caulked along the edges, overhang and drip groove.
- Mortar joints are normally the location where moisture gets through the brickwork. Three factors are important. The first is that the joints should be filled at least 75% full. The second is consistent mortar proportions; 1 bag mortar mix to 3 cu. feet (0.085 m³) of sand. The third is that the mortar should be wet enough to ensure good bond.
- A building wrap, felt paper or similar material, is suggested as additional moisture protection. It covers the sheathing board and joints.

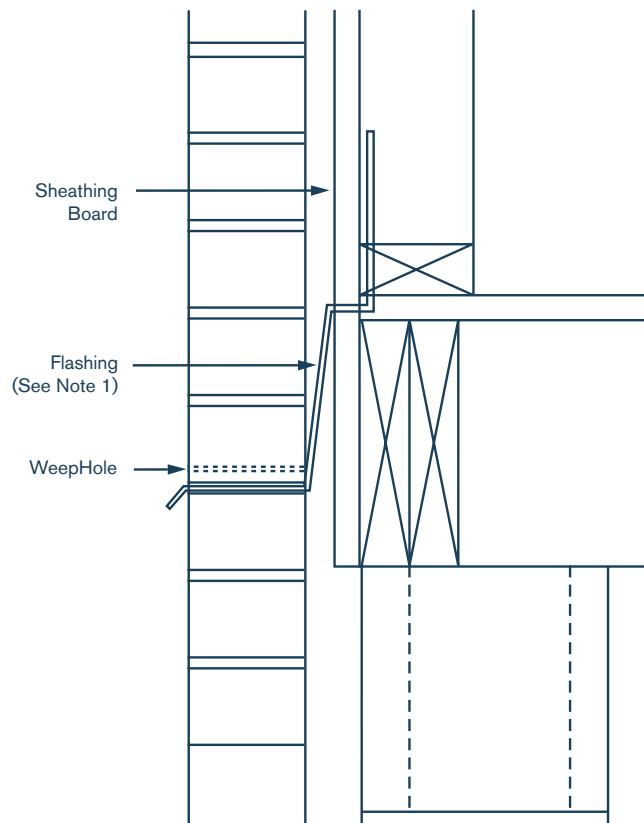

Detail 1
Flashing at First Floor, Over Crawl Space

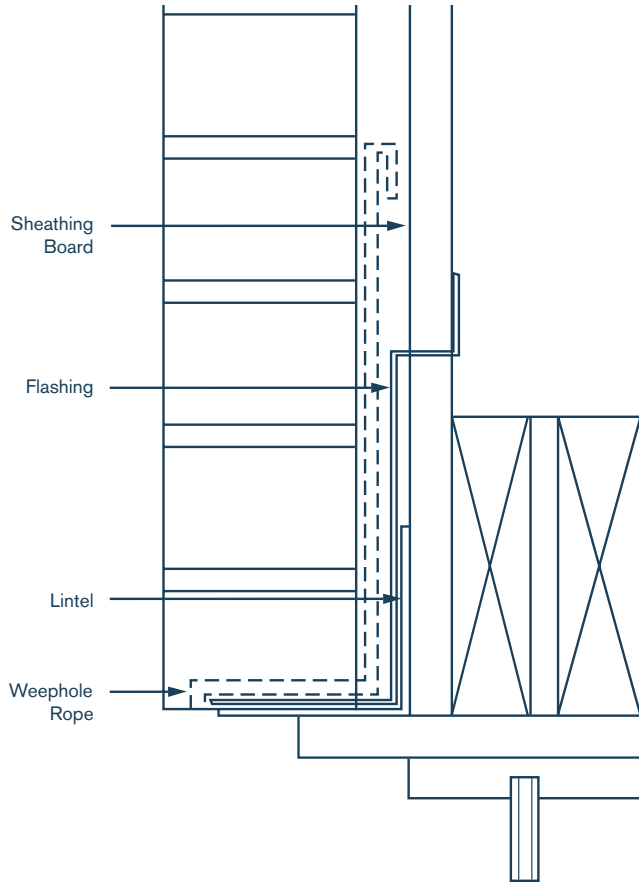

Detail 2
Flashing at Door/Window Head

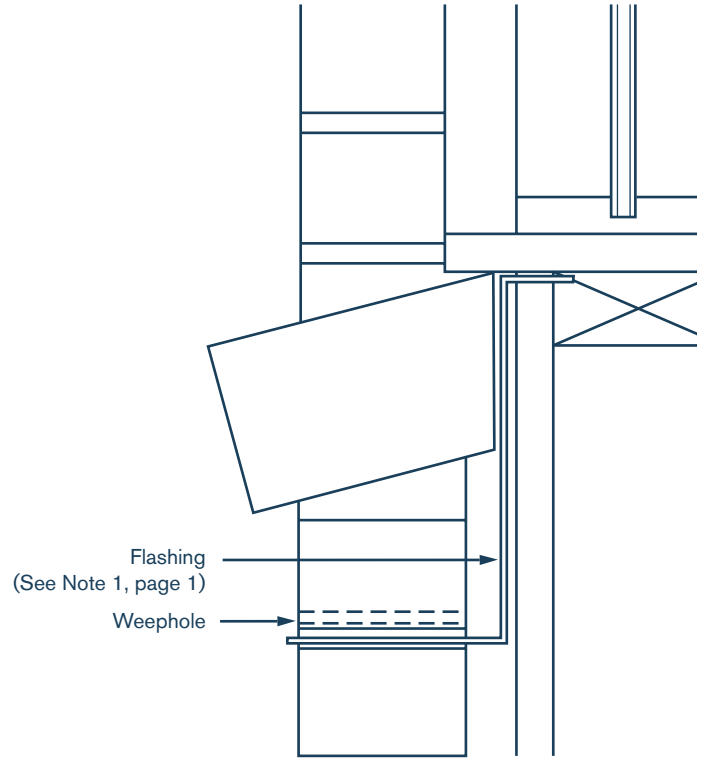

Detail 4
Flashing at Window Sill
Optional - Leave Flashing Out of Mortar Joint

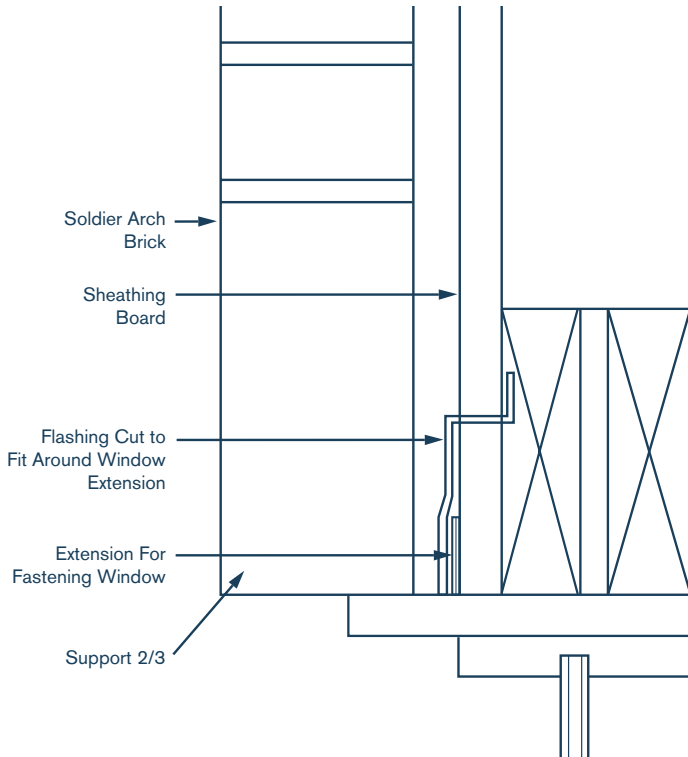

Detail 3
Flashing at Head of Curved Door/Window Opening

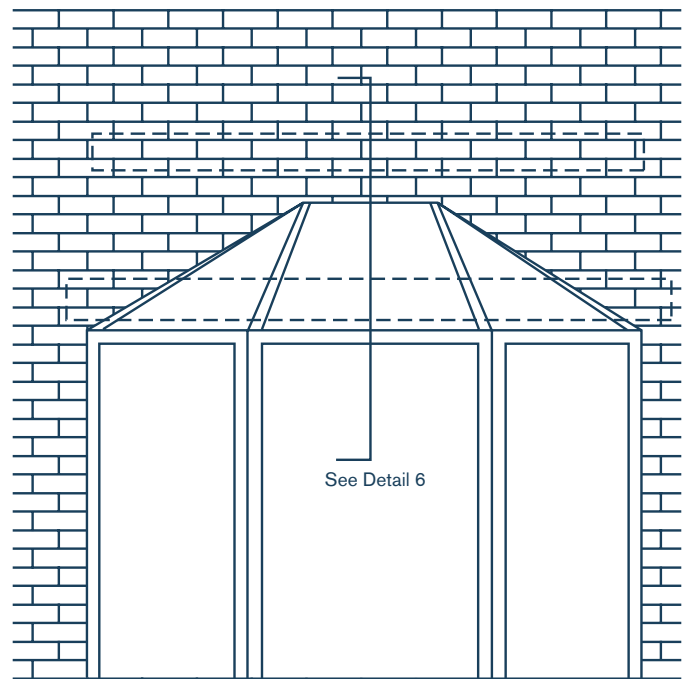

Detail 5
Bay Window Elevation with Thru-Wall Flashing

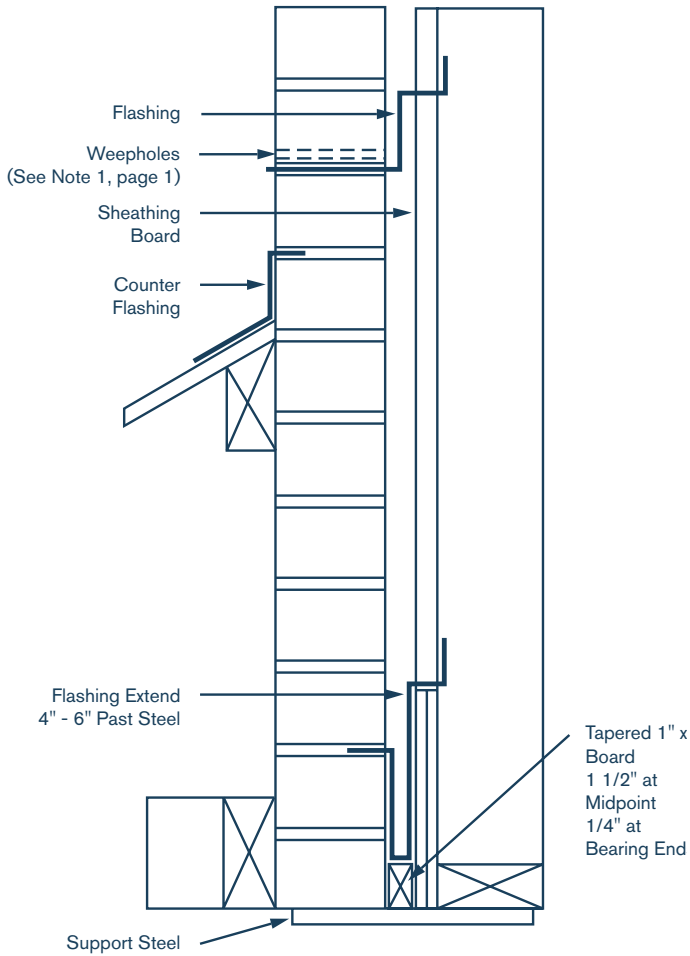

Detail 6
Flashing at Bay Window Head

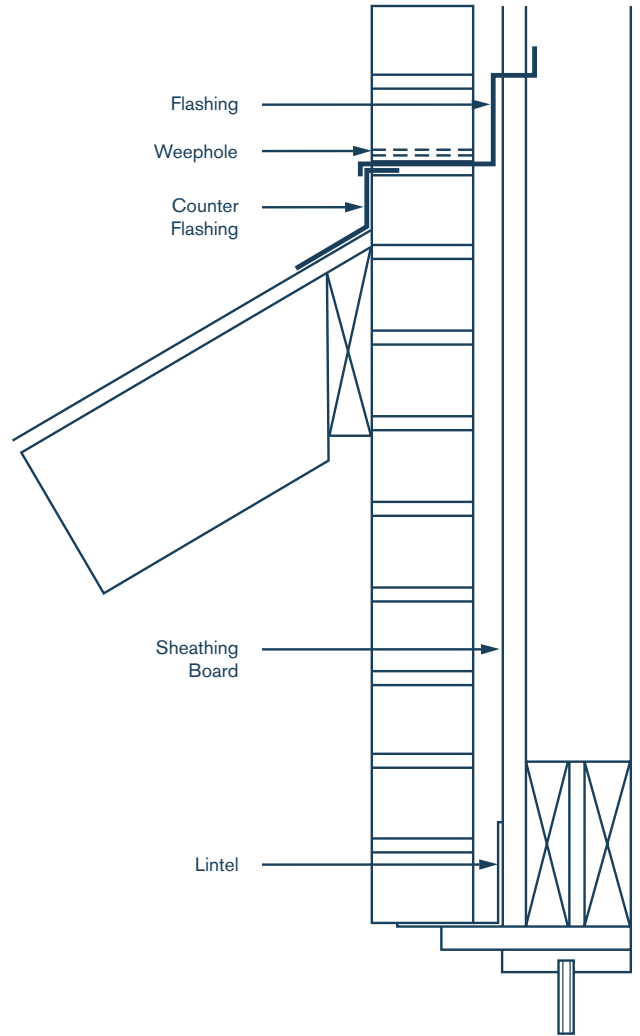

Detail 7
Flashing at Low Roof Over Enclosed Space

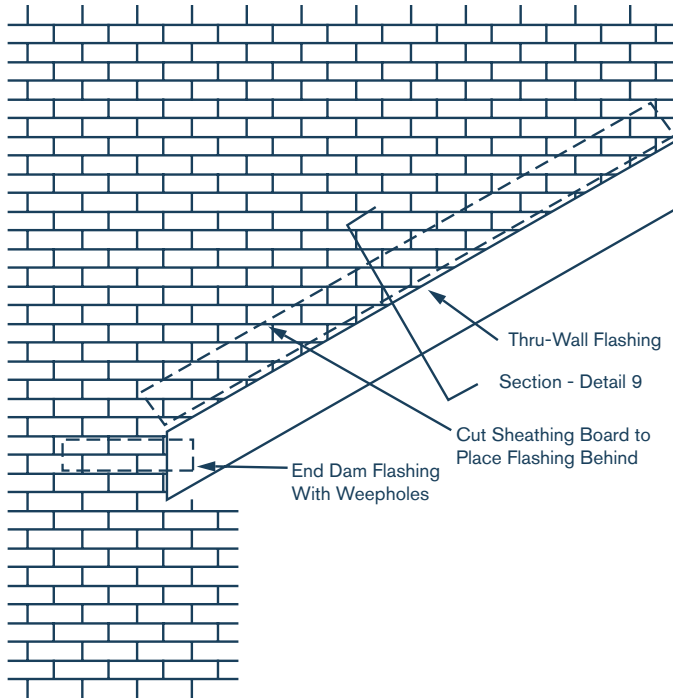

Detail 8
Flashing at Low Roof, Supporting Brick

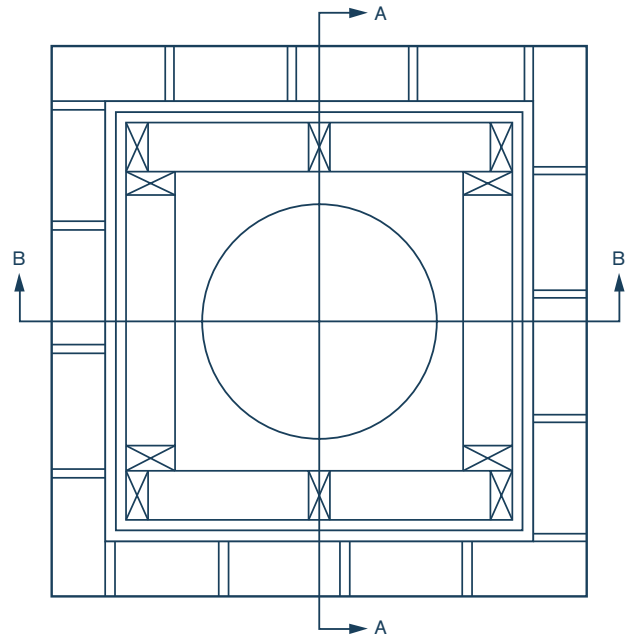

Detail 10
Plan View - Prefab Chimney

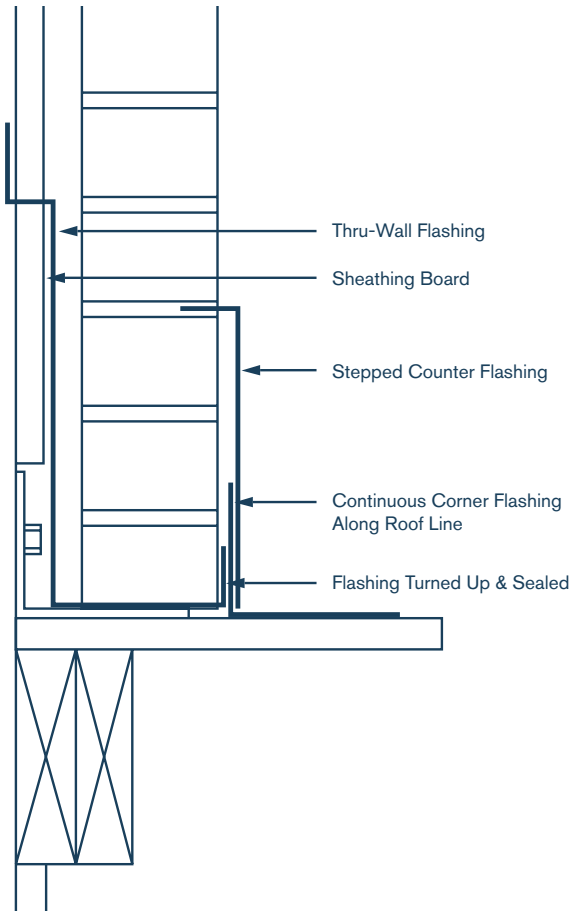

Detail 9
Flashing Section at Sloping Low Roof (See Detail 8)

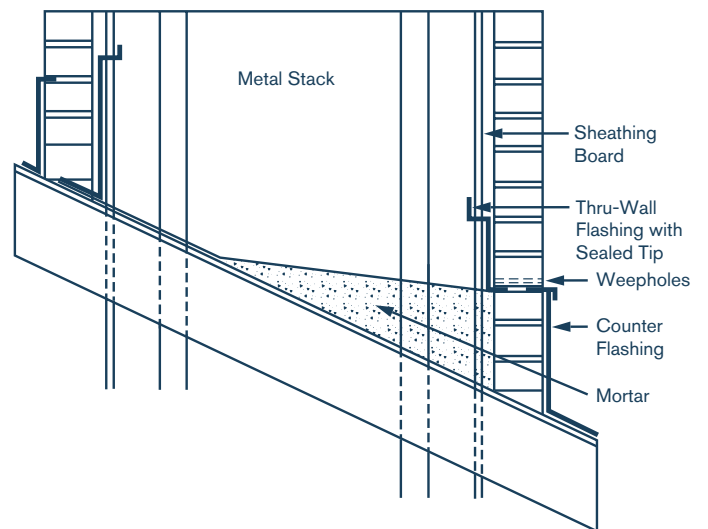

Detail 11
Section A-A, Prefab Chimney

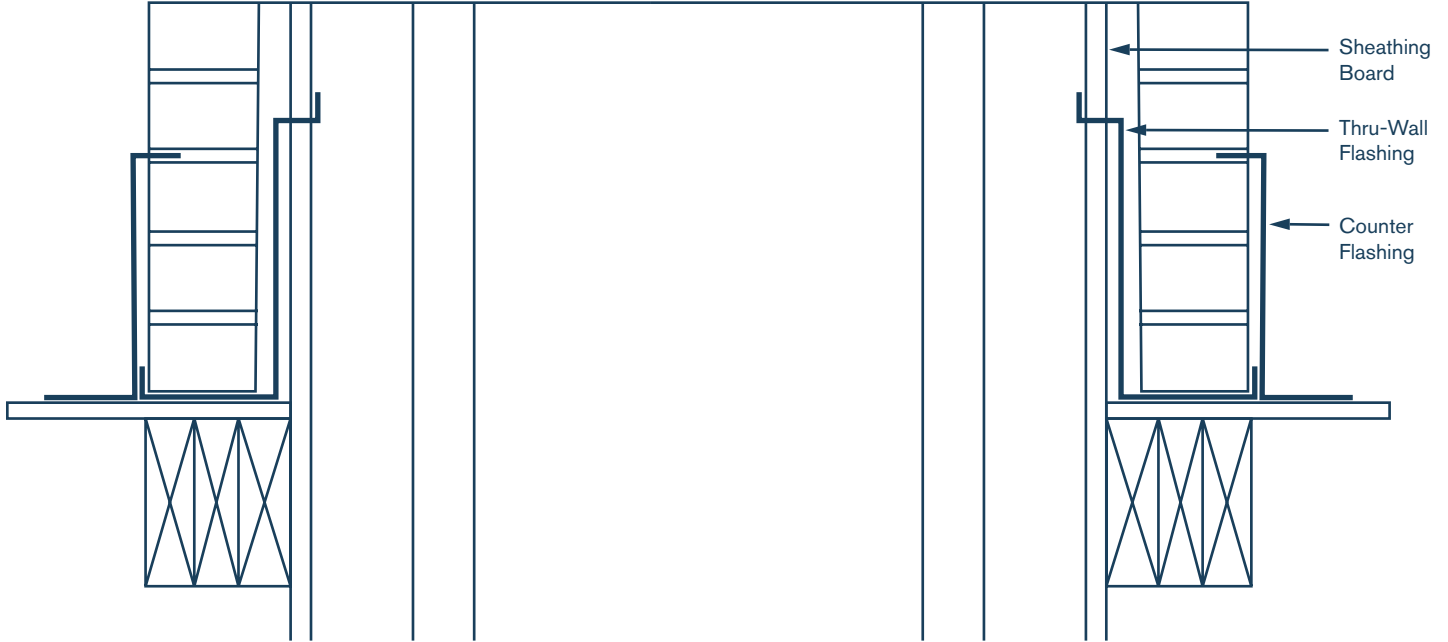

Detail 12
Section B-B, Prefab Chimney

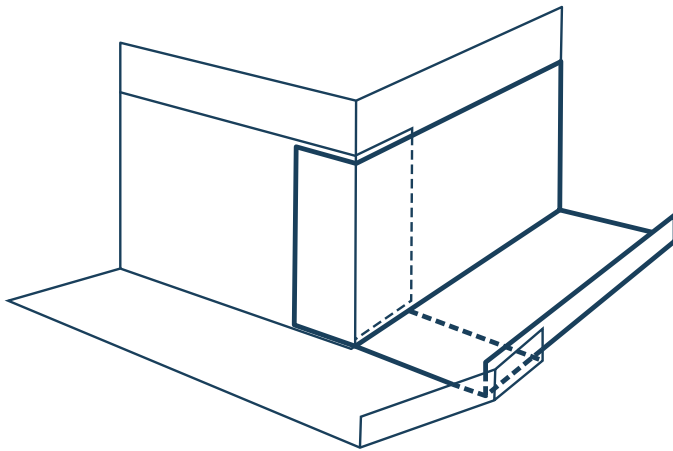

Detail 13
Lower Corner Flashing, Prefab Chimney

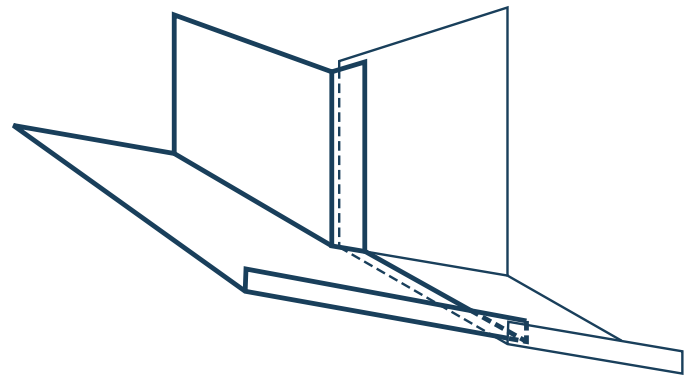

Detail 14
Upper Corner Flashing, Prefab Chimney